



咖啡胶囊包装专家

SINGLE SERVE PACKAGING EXPERT

苏州诚派进出口有限公司
Suzhou Expak Packaging Co., Ltd

联系电话/传真: 0512-83991006
邮箱: sales@expakchina.com
地址: 苏州市工业园区扬云路2号

国内业务: 13348016660
网址: www.expakchina.com
邮编: 215000

Add: No.2, Yang Yun Road, Suzhou city, Jiangsu state, China
Office: +86-512-83991006
E-mail: sales@expakchina.com
Aftersales: support@expakchina.com

Mobile: +86-13348016660
supply@expakchina.com
Website: www.expakchina.com



EX Pak®

苏州诚派进出口有限公司

SUZHOU EXPAK PACKAGING CO., LTD

关于我们 ABOUT US

技术创新 胶囊专家

我司始创于2010年，位于江苏省苏州市工业制造集聚区域，工厂面积5000平米，是一家专业研发、制造、销售创新型容器灌装包装机械设备、自动化控制生产机械的江苏省高新技术企业，以咖啡胶囊灌装设备，单杯饮料产品的灌装封口压盖，纸盒装盒自动化设备为特色，从创立之初始终坚持技术不断突破，持续领先国内同类设备3-5年以上，中国市场占据90%以上，大量出口国外市场包括欧洲北美等。自2016年起，针对国内市场，我司创立子公司美惠加食品有限公司，通过中国SC认证，有PODMATE系列胶囊饮品，并承接各类代工生产业务。



Technical innovation Expert of Capsule packaging

EXPAK Packaging was founded in 2010, located in Suzhou, one-hour drive to Shanghai airport. Our workshop is 12000 m², we are China's first and only machinery manufacturing unit that design our machine from zero to fit single serve production. Upon our R&D, manufacturing team continues effort, we have been leading the industry 3-5 years in advance. Featured products as: single serve coffee capsule filling and sealing machine, capsule box packaging system. Sales of packaging material for empty capsule cup, filters, sealing lids etc.

We have reached over 90% of China domestic market and have supplied our machinery all over the world and set up local after-service in Euro and USA.

Since 2016, new branch company-Podmate launched to produce coffee capsules and other food products for China market and have passed China SC food safe certification.



企业荣誉资质 CERTIFICATIONS

公司不懈努力，顺利通过CE认证，ISO管理体系认证以及UL间接认证，并获得省级科技创新企业认证。

Upon continues efforts, we have obtained many technical invention patents, and passed CE certificate, ISO9001 Quality management certification as well as UL certification, also won the state-level science and technology corporation title of Jiangsu.



Invention Patents



China CQC认证



ISO9001-2008



"CE"产品认证

企业理念 CONCEPTS AND PURPOSE

专业研发，精益求精

Professional R&D and machinery manufacturing

快速响应，完整服务

Fast response and complete service

灵活定制，多样化合作

Flexible customize and variety partnership

■ 专业研发，精益制造

公司自创办以来以胶囊灌装封口设备为起点，从零开始设计开发并不断升级的CP50-02,CP50-04,CP50-06, CPL2501,CPR4501 系列（匹配Nespresso, Dolce Gusto, Kcup, Lavazza Blue, Lavazza Point, coffee pod等兼容型胶囊），逐渐延伸到完整后道包装自动化方案。包括PBX1装盒机散装Nespresso及Dolce Gusto胶囊，以及PBX2系列用于KCUP的12个，24个等上下翻转的零售纸盒自动化包装系统。从生产实际需求出发，结构合理，精度高，稳定可靠，赢得国内外客户的高度赞誉。



伺服驱动高精度灌装
Servo motor driven filler (Electric upon Schneider system)



触摸屏人机交互
Touchscreen interface (PLC upon OMRON platform)



气动机械手抓杯模块
Manipulator and robots (Pneumatic platform upon SMC)

■ Professional R&D & specialized in machinery manufacturing
Dedicated for single serve capsule packaging

The start-up of company is for coffee capsule, we are China's first and only designed first machine from zero to fit for coffee capsule production use. Now we have CP50-02,CP50-04,CP50-06, CPL2501,CPR4501 for compatible capsules : Nespresso, Dolce Gusto, Kcup, Lavazza Blue etc. systems. Also, second packaging: PBX1 for free-fall Nespresso 10ct paper box, PBX2 to pack Kcup in 12ct, 24ct, upside down to each, retail paper box. Meet actual production needs, simple structure, high accuracy, and excellent reliability, so highly accepted and many repeat customers.



CNC加工中心
CNC Center



金属加工自主生产
Own metal working



模块化电器组装
Module assembling for electric

■ 快速响应，完善服务

我司具备完整的技术咨询，专业的培训，以及完善的售后服务团队。对于设备提供18个月质保期以及终身技术支持服务。任何情况保证24小时响应，在国内48小时内发货各项易损配件，并且拥有欧洲美国本地化的代理商服务。

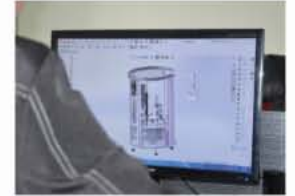

■ Fast response and complete service

We have professional team for: technical consultant, training before shipping and after sales service team. Warranty for our manufactured machines are 18 months. Fast response within 24 hours and regular spare parts be sent within 48hours upon China inventory, overseas we have EURO and USA local agents giving technical support and parts inventory.



Delivery time: 20-45days
Inventory for parts ready in factory
48hours response with DHL FEDEX



Overseas service available
USA distributor facility



■ 灵活定制, 多样化合作

Flexible customize and variety partnership

公司的产品只以标准化系列的结构平台作为基础, 所有的工位功能以及拓展项目, 是依靠十多年来积累的各种可选方案进行匹配组合, 每台设备按照每个客户的实际需求进行一对一定制生产以最大化符合客户的实际生产要求。

另外, 依托专业的产业链背景和合作伙伴支持, 公司创新推出两项双赢合作模式: 一是包装材料打包方式, 完整方案保证质量和可行性, 延长保质期到终身制。二是试订单代加工方式, 先做产品测试市场, 再决定是否客户自行采购设备自己生产 (暂时只针对国内客户)。

Our machines are based on standard platforms (latest asCP50, CP45R, CPL25), but every customer has different requirements, so for each function station as well as optional extra options, you can choose from prepared different technologies and solutions, which is based on past 10 years experience, hence maximize customer production benefits. Besides traditional machinery purchase,

we also have two new modes, one is packaging material supply package together with machine, to guarantee solution works and extend warranty to be lifelong. Second is product trial order put to Podmate so you can test the market then to decide purchase machinery and launch your own production(currently for China market only).



Co-packing service for China market.



Nevada warehouse



Inventory of kcups supply

物料种类 TYPICAL MATERIALS KINDS



颗粒类: 现磨咖啡粉 (极细研磨和中粗研磨)
Granule: Ground coffee (fine or course grinding)



粉末类: 奶粉, 巧克力粉, 速溶咖啡
Powder: like Milk powder, chocolate, instant coffee



原粒原叶: 干果, 花茶, 茶叶原叶, 咖啡豆
Leaf & big granule: Herbal, dry nuts, tea leaf

成品 FINISHED SAMPLES



CPL-2501

全自动胶囊灌装封口机

Linear Coffee Capsule Filling And Sealing Machine



主要特点

- > 机器体积小，占地少，简单，易操作。
- > 整机采用304不锈钢机身，有机玻璃门结构带开门停机功能，以确保人员操作安全
- > 功能完整并自动化作业。
- > 高精度伺服螺杆保证灌装偏差小。
- > PLC控制，全程生产及时显示。
- > 氮气置换系统：从落杯至封口前全程氮气保护，残氧量仅5%
- > 无杯不灌装、不封口、启动自动剔废功能：由于个别杯子未能入模板、检测故障后，对该模板不灌装、不吸膜、不封口。

Main features

- > Small size, simple, easy to learn and start up.
- > Machine framework use SS304, with plexi glass doors and automatic stop when door open (protect operator).
- > Complete functions and full automatic.
- > High accurate motor driven by servo motor.
- > PLC controller and real-time monitoring.
- > Nitrogen flush: from empty capsule loaded until capsule sealed.
- > No cup no filling and no sealing (continues production no pause)

适用范围（卷膜、片膜均可）

适用于各种颗粒状、粉状、液体等物料的称重。
如咖啡、奶粉、豆奶粉、茶叶、花茶、速溶粉、酸奶等食品物料。
适用胶囊类型（类Nespresso、DolceGusto、LavazzaBlue、Point、POD、K-CUP、Kshot、One Cup等）

Applicable Range

The machine is suitable for various granule, powder and liquid materials. Such as coffee, milk powder, tea, instant soluble powder, yogurt and other food materials.
Applicable capsule: Compatible Nespresso, DolceGusto, Lavazza Blue, Point, POD, K-CUP, Kshot, One Cup

标准功能和工位

- > 自动落杯带检测
 - > 自动灌装（灌装精度达到±0.1g）
 - > 真空自动上料
 - > 自动吸杯口粉尘
 - > 自动吸膜、放膜带片膜检测
 - > 检测片膜并完成封口（平封或者线封）
 - > 成品自动出杯
 - > 自动记录包装产品数量
 - > 故障报警提示功能
- 可选功能：
- > 空杯紫外线杀菌
 - > 高精度加液系统（加香精等液体）
 - > 螺杆机械式上料替代真空上料
 - > 成品称重和自动剔废
 - > 远程网口连接实现远程监控和软件升级

Standard functions and optionals

- > Auto load empty capsule and sensor check.
 - > Filling material(±0.1g)
 - > Hopper material reloaded by vacuum conveyor lifter.
 - > Auto clean the cup edge.
 - > Grab foil lid and place ready on cup.
 - > Check lid in position and seal (flat seal or ring curve seal)
 - > Finished capsule grab out.
 - > Automatic count production quantity.
 - > Automatic alarm to remind operator
- Optional
- > UV lamp sterilize
 - > High precise liquid flavoring pump
 - > Auger conveyor lifter (replace the vacuum conveyor)
 - > Finished capsule checker weigher and reject unqualified
 - > Internet port connection, remote control and online upgrade.

型号 Model	CPL-2501 卷切膜 Roll foil	CPL-2501 片膜 Precut lid
单次灌装范围 Filling weight range	0-20g*n (可定制)	0-20g*n (可定制)
灌装精度范围 Filling accuracy	±0.01~0.1g	±0.01~0.1g
最高速度 Speed	30 (杯/分钟) 30Cups/minute	30 (杯/分钟) 30Cups/minute
料斗容量 Hopper capacity	1.0L(2.5L)可选110L Option	1.0L(2.5L)可选110L Option
控制系统 Controlsystem	PLC	PLC
显示器 Displayer	7寸触摸屏 7 Inch touchscreen	7寸触摸屏 7 Inch touchscreen
电源要求 Power	AC220V/380V 50Hz/60Hz	AC220V/380V 50Hz/60Hz
包装尺寸 Dimension	2490(L)*1250(W)*2100(H)mm	2035(L)*670(W)*1920(H)mm
机器重量 Weight	600kg	580kg
发货重量 Gross weight	650kg	620kg

CPL-2501D

全自动咖啡胶囊灌装封口机

Dolce Gusto And Lavazza Point Capsule

Filling And Sealing Machine

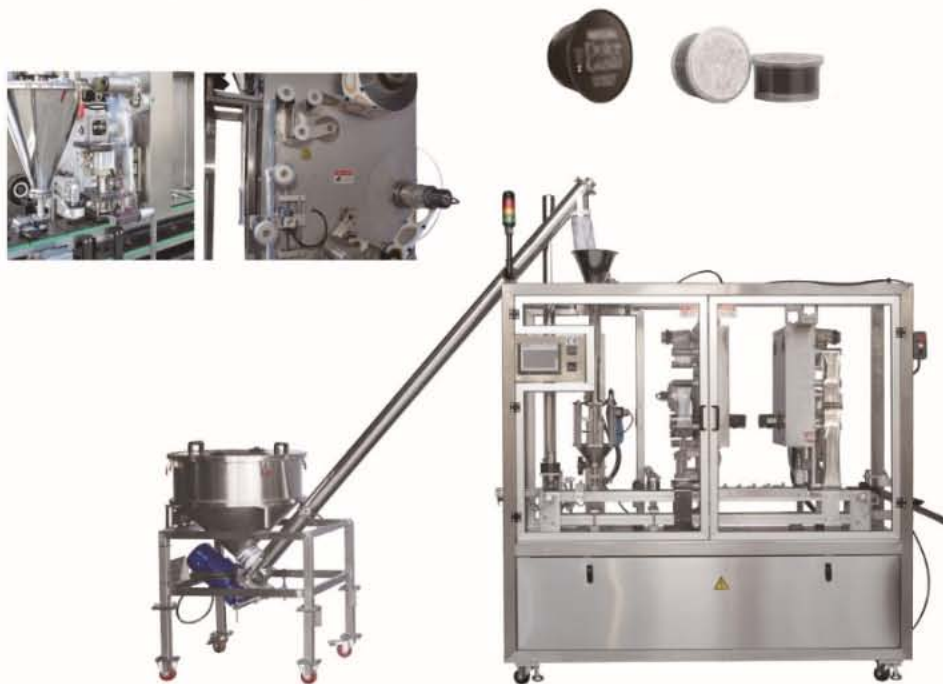

主要特点

- > 两次封口功能
- > 机器体积小，占地少，简单，易操作。
- > 整机采用304不锈钢机身，有机玻璃门结构带开门停机功能，以确保人员操作安全
- > 高精度伺服螺杆保证灌装偏差小。
- > PLC控制，全程生产及时显示。
- > 高级氮气系统：在封外膜时做氮气置换，残氧量仅5%
- > 无杯不灌装、不封口、启动自动剔除功能：由于个别杯子未能入模板、检测故障后，对该模板不灌装、不吸膜、不封口。

Main features

- > Two sealing stations.
- > Small size, simple, easy to learn and start up.
- > Machine framework use SS304, with plexi glass doors and automatic stop when door open (protect operator).
- > High accurate motor driven by servo motor.
- > PLC controller and real-time monitoring.
- > Upgrade type Nitrogen system: flush capsule when outside sealing(Remained Oxygen Level as low as 5%)
- > No cup no filling and no sealing (continues production no pause)

适用范围（卷膜、片膜均可）

适用于二次滤纸膜封口型胶囊
适合各种颗粒状、粉状物料如研磨咖啡、奶粉、豆奶粉、茶叶、花茶等。
典型应用胶囊类型:Nespresso带过滤纸, lavazza point带过滤纸, Dolce gusto 咖啡胶囊带内膜。

标准功能和工位

- > 自动落杯带检测
 - > 底部过滤纸封口膜(Nespresso 和Lavazza配置)
 - > 自动灌装（灌装精度达到±0.1g）
 - > 真空自动上料
 - > 自动吸杯口粉尘
 - > 内膜封口压住咖啡粉（多趣酷思咖啡胶囊配置）
 - > 自动吸膜、放膜带片膜检测
 - > 检测片膜并完成封口（平封或者线封）
 - > 成品自动出杯
 - > 自动记录包装产品数量
 - > 故障报警提示功能
- 可选功能：
- > 空杯紫外线杀菌
 - > 高精度加液系统（加香精等液体）
 - > 螺杆机械式上料替代真空上料
 - > 成品称重和自动剔除
 - > 远程网口连接实现远程监控和软件升级

Applicable Range

Extended to be able to do two times roll cut and seal, Suitable to fit for ground coffee, powders, herbal tea. Typical for: Nespresso with bottom filter paper, Lavazza Point with bottom filter and Dolce Gusto espresso coffee with inner filter film.

Standard functions and optionals

- > Auto load empty capsule and sensor check.
 - > Bottom filter film seal(for Nespresso and Lavazza capsules)
 - > Filling material(±0.1g)
 - > Hopper material reloaded by vacuum conveyor lifter.
 - > Auto clean the cup edge.
 - > Inner film seal and cover the coffee
 - > Grab foil lid and place ready on cup.
 - > Check lid in position and seal (flat seal or ring curve seal)
 - > Finished capsule grab out.
 - > Automatic count production quantity.
 - > Automatic alarm to remind operator
- Optional:
- > UV lamp sterilize
 - > High precise liquid flavoring pump
 - > Auger conveyor lifter (replace the vacuum conveyor)
 - > Finished capsule checker weigher and reject unqualified
 - > Internet port connection, remote control and online upgrade.

型号 Model	CPL-2501D(片膜、卷膜可选) Precut lid or Roll film cut
单次灌装范围 Filling weight range	0-20g*n(可定制)
灌装精度范围 Filling accuracy	±0.05~0.15g
最高速度 Speed	25-30 (杯/分钟) Cups/per minute
料斗容量 Hopper capacity	10(2.5L)可选110L
控制系统 Controlsystem	PLC
显示器 Displayer	7寸触摸屏 7 Inch touchscreen
电源要求 Power	AC220V/380V 50Hz/60Hz 1.2KW
机器尺寸 Dimension	2350mm(L)*1250mm(W)*2200mm(H)
机器重量 Weight	600kg
发货重量 Gross weight	640kg

CPR-4501

圆盘型咖啡胶囊灌装封口机

Rotary Type Coffee Capsule Filling And Sealing Machine



■ 主要特点

- > 机器体积小，产量可观
- > 功能完整并自动化作业。
- > 高精度伺服螺杆保证灌装偏差小。
- > PLC触摸屏控制，全程生产及时显示。
- > 氮气系统：在封外膜时做氮气置换，残氧量仅5%
- > 无杯不灌装、不封口。

■ 适用范围（卷膜、片膜均可）

各种颗粒状、粉状物料如研磨咖啡、奶粉、豆奶粉、茶叶、花茶等。典型应用胶囊类型：Nespresso, Kcup, Dolce Gusto 胶囊等

■ Main features

- > Small size, higher speed capacity.
- > Complete functions and full automatic.
- > High accurate motor driven by servo motor.
- > PLC controller and real-time monitoring.
- > Nitrogen system: flush capsule
- > No cup no filling no sealing(continues without stop)

■ Applicable Range

Suitable to fit for ground coffee, powders, herbal tea. Typical for: Nespresso ,Kcup, Lavazza Blue, Instant Dolce Gusto.

■ 标准功能和工位

- > 自动落杯带检测
- > 自动灌装（灌装精度达到±0.1g）
- > 自动吸杯口粉尘
- > 自动吸膜、放膜带片膜检测
- > 检测片膜并完成封口（平封或者线封）
- > 成品自动出杯

■ Standard functions and optionals

- > Auto load empty capsule and sensor check.
- > Filling material into capsule (±0.1g)
- > Auto clean the cup edge.
- > Grab foil lid and place ready on cup.
- > Check lid in position and seal (flat seal or ring curve seal)
- > Finished capsule grab out.



型号 Model	CPR-4501(片膜、卷膜可选) Precut lid or Roll Film
单次灌装范围 Filling weight range	0-20g*n(可定制)Option
灌装精度范围 Filling accuracy	±0.05-0.15g
最高速度 Speed	50-80 (杯/分钟) Cups/per minute
料斗容量 Hopper capacity	10(2.5L)可选110L
控制系统 Controlsystem	PLC(Omron)
显示器 Dispalyer	7寸触摸屏 7 Inch touchscreen
电源要求 Power	AC220V/380V 50Hz/60Hz 1.2KW
机器尺寸 Dimension	1750mm(L)*1300mm(W)*2200mm(H)
机器重量 Weight	710kg
发货重量 Gross weight	760kg

CP5002N

两列雀巢咖啡胶囊灌装封口机

Two Lane Type Nespresso Capsule Filling Sealing Machine



■ 适用范围（卷膜、片膜均可）

各种颗粒状、粉状物料如研磨咖啡、奶粉、豆奶粉、茶叶、花茶等。
典型应用胶囊：Nespresso 兼容铝胶囊或塑料胶囊。

■ 标准功能和工位

- > 自动落杯带检测
- > 自动灌装（灌装精度达到 $\pm 0.1g$ ）
- > 自动吸杯口粉尘
- > 自动吸膜、放膜带片膜检测
- > 检测片膜并完成封口（平封或者线封）
- > 成品自动出杯到输送带

可选功能：

- > 高精度加液系统（加香精等液体）
- > 螺杆机械式上料替代真空上料
- > 成品称重和自动剔除
- > 远程网口连接实现远程监控和软件升级

■ Applicable Range

Suitable for ground coffee, powders, herbal tea.
Typical for: Nespresso Aluminum or Nespresso PP/PBT.

■ Standard functions and optionals

- > Auto load empty capsule and sensor check.
- > Filling material into capsule ($\pm 0.1g$)
- > Auto clean the cup edge.
- > Grab foil lid and place ready on cup.
- > Check lid in position and seal (flat seal or ring curve seal)
- > Finished capsule grab out and put on belt

Optional

- > High precise liquid flavoring pump
- > Auger conveyor lifter as reload (replace the vacuum conveyor)
- > Finished capsule checker weigher and reject unqualified
- > Internet connection, remote diagnose control and online upgrade.

■ 主要特点

- > 高度自动化，单位成本低，大批量生产担当。
- > 高级氮气系统：标配高级氮气置换系统，残氧量少于5%

■ Main features

- > Automatic, low unit cost, heavy duty production.
- > Upgrade Nitrogen system: Nitrogen flush Oxygen Remain within 5%



水平落杯系统
Horizontal loading system



片膜工位
Precut lids



卷膜工位
Roll film station



垂直落杯工位
Vertical loading station



成品输出到输送带
Grab out and put on belt

型号 Model	CP5002N(片膜/卷膜) Precut lid or Roll Film
单次灌装范围 Filling weight range	0-20g
灌装精度范围 Filling accuracy	$\pm 0.05-0.15g$
最高速度 Speed	80-100 (杯/分钟) Cups/per minute
料斗容量 Hopper capacity	10-24L可选110L
控制系统 Controlsystem	PLC(Omron or customize)
显示器 Dispalyer	10寸触摸屏 10 Inch touchscreen
电源要求 Power	220V/380V 50Hz/60Hz 5KW
机器尺寸 Dimension (垂直落杯Vertical load)	3420mm(L)*850mm(W)*2700mm(H)
机器尺寸 Dimension (水平落杯Horizontal load)	4560mm(L)*850mm(W)*2300mm(H)
机器重量 Net/Packed Weight	950kg/970kg

CP5004N

雀巢胶囊灌装封口装盒生产线

4 Lane Nespresso Capsule Filling Sealing Machine With 10ct PaperBox Packaging Machine

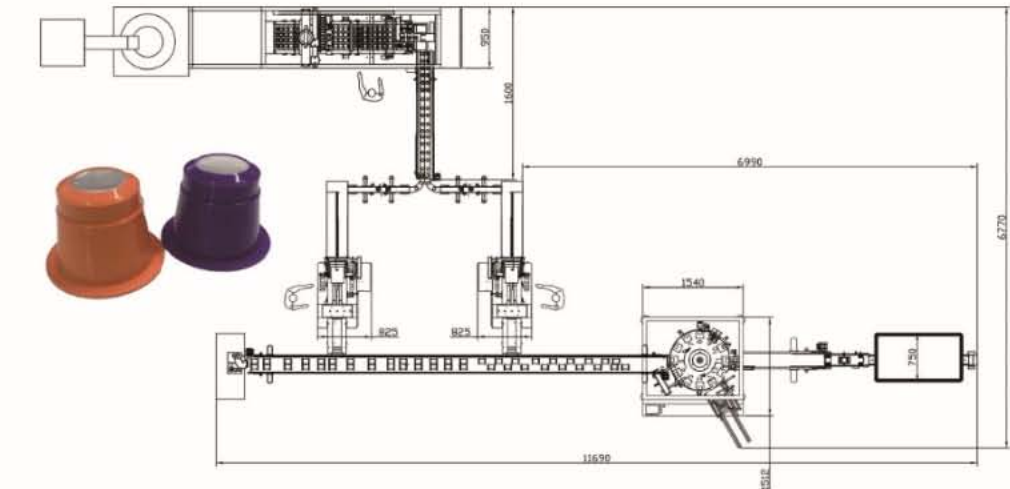
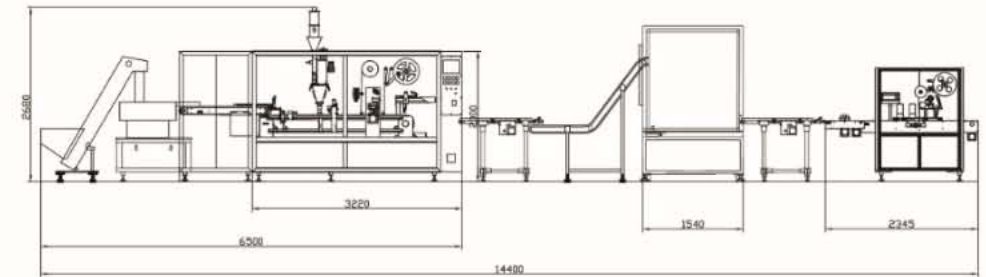

型号 Model	CP5004N (卷膜/片膜) Precut lid or Roll Film
单次灌装范围 Filling weight range	0-20g*n (可定制) Option
灌装精度范围 Filling accuracy	±0.05~0.15g
最高速度 Speed	150-200 (杯/分钟) Cup per minute
料斗容量 Hopper capacity	10-24L 可选110L Option
控制系统 Controlsystem	PLC (Omron or customize)
显示器 Displayer	10寸触摸屏 10 Inch touchscreen
电源要求 Power	AC220V/380V 50Hz/60Hz 7KW
灌装机器尺寸 Filler Dimension	3420(L)*850(W)*2700(H)mm
整线尺寸 Complete Line Dimension	14560(L)*850(W)*2300(H)mm
机器重量 Net/Packed Weight	1500kg/1700kg

CP5002K/CP5004K

Kcup胶囊灌装封口生产线
Linear Type Kcup Filling Sealing Machine

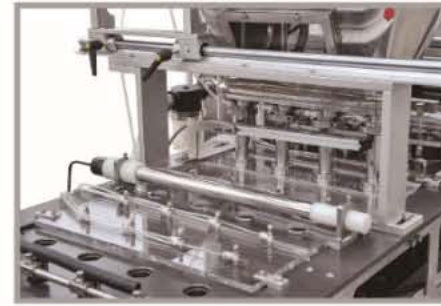

型号 Model	CP5002K (卷膜、片膜可选) Precut lid or Roll Film	CP5004K nespresso Precut lid or Roll Film
单次灌装范围 Filling weight range	0-20g*n (可定制)	0-20g*n (可定制)
灌装精度范围 Filling accuracy	±0.05~0.15g	±0.05~0.15g
最高速度 Speed	60-100 (杯/分钟) Cups/minute	120-200 (杯/分钟) Cups/minute
料斗容量 Hopper capacity	2.5-110L可选Option	2.5-110L可选 Option
控制系统 Controlsystem	PLC(欧姆龙、施耐德、罗克韦尔) (OMRON, SCHNEIDER, ROCKWELL)	PLC(欧姆龙、施耐德、罗克韦尔) (OMRON, SCHNEIDER, ROCKWELL)
显示器 Displayer	10寸触摸屏 10 Inch touchscreen	10寸触摸屏 10 Inch touchscreen
电源要求 Power	AC220V/380V 50Hz/60Hz	AC220V/380V 50Hz/60Hz
包装尺寸 Dimension	4800(L)*1000(W)*2100(H)mm	(3720+1750)*1200mm
机器重量 Weight	960kg/1000kg	1150kg/1250kg

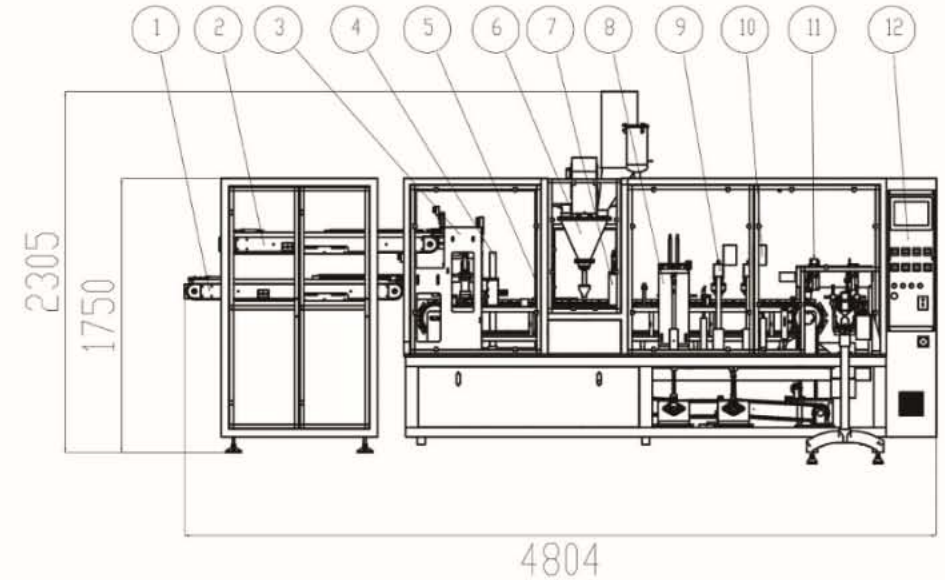

PBX2

Kcup胶囊自动装盒系统

PBX2-Kcup Paper Box Packaging System

- Typical for 12ct/24ct/36ct paper box
- Hot glue system is Miller or Nordson

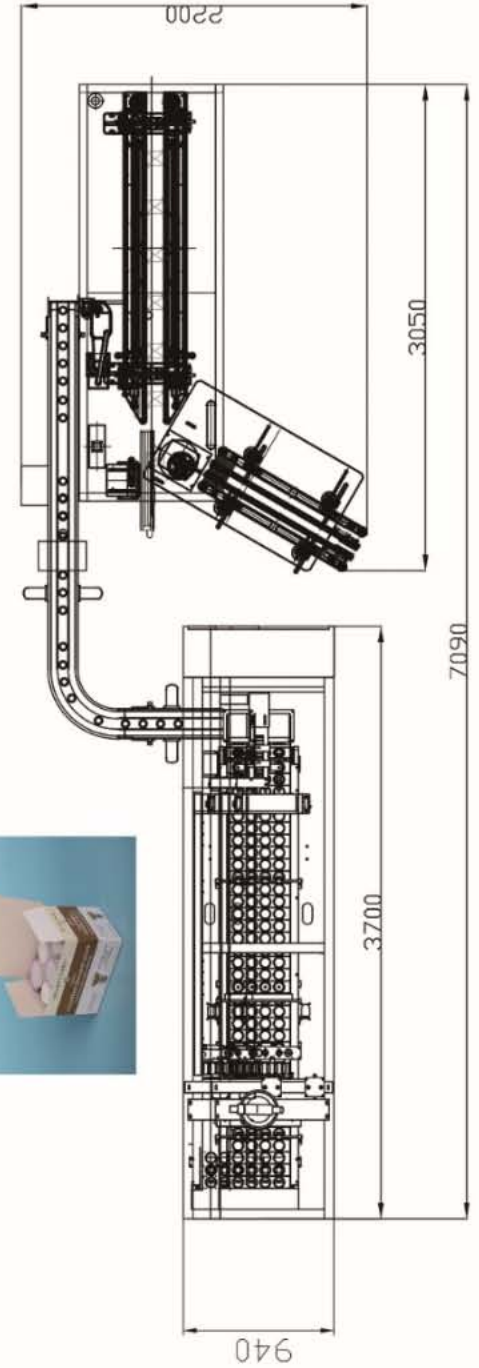
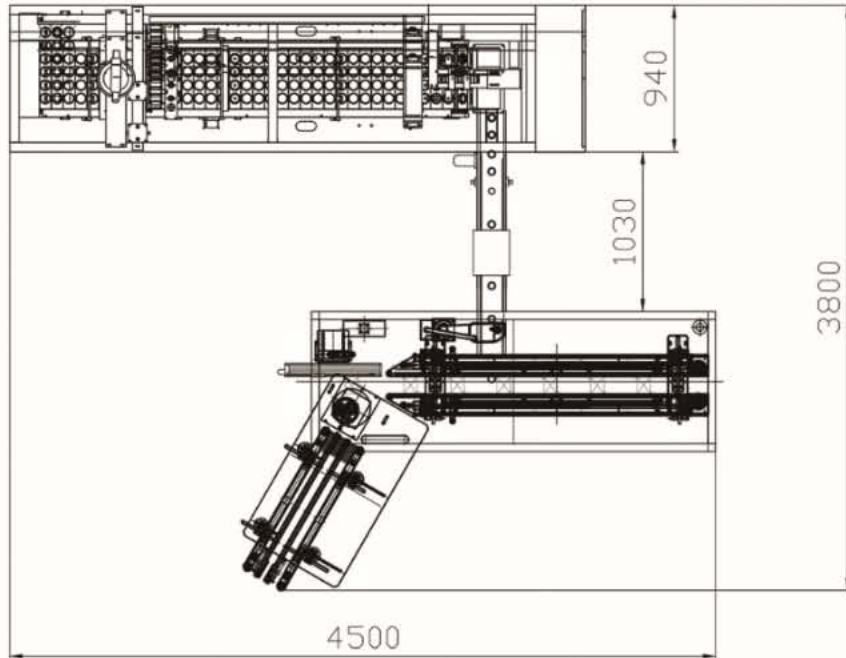

PBX2 装盒系统包括:

- 1 成品自灌装接收后的输送连接
 - 2 胶囊整理和翻转 (选装)
 - 3 开盒装盒完毕
 - 4 热熔胶自动头盒输出
- PBX2 Box Packing System Includes:**
- 1 sealed kcup receive and conveyor connection
 - 2 turn over upsides down to each (optional)
 - 3 open box and load groups
 - 4 hot melt glue seal the box and output

CP02DG/CP04DG

多趣酷思咖啡胶囊灌装生产线

2-Lane 4-Lane Dolce Gusto Coffee Capsule Packing Machine



型号 Model	CP02DG/CP04DG (卷膜) cutting film
单次灌装范围 Filling weight range	0-20g
灌装精度范围 Filling accuracy	±0.05~0.15g
两列速度 2 lane capacity speed	60-100 (杯/分钟) Cups/per minute
四列速度 4 lane capacity speed	140-200 (杯/分钟) Cups/per minute
料斗容量 Hopper capacity	10-24L可选110L
控制系统 Controlsystem	PLC
显示器 Displayer	10寸触摸屏 10 Inch touchscreen
电源要求 Power	220V/380V 50Hz/60Hz 5KW
机器尺寸 Dimension	5850mm(L)*4490mm(W)*2200mm(H)
机器重量 Weigh/发货重量 Gross weightt	1200kg/1500kg

主要特点

- > 适用于多趣酷思胶囊
- > 物料类型：粉体，花茶，研磨咖啡粉。
- > 针对咖啡粉，含内外膜两次封口系统。
- > 高级氮气系统：标配高级氮气置换系统，残氧量少于5%

Main features

- > Specially for Dolce Gusto compatible capsules.
- > Material fits: Soluble powder, herbal tea leaf, fresh ground coffee.
- > For coffee espresso capsule including the inner film sealing.
- > Upgrade Nitrogen system: Nitrogen flush Oxygen Remain within 5%



PBX-F

自动掉落装盒机

Paper Box Packing System(Free Fall)



主要特点

- > 常规适用：多趣酷思和Nespresso胶囊
- > 包括自动开盒，送料，关盒
- > 热熔机喷胶和日期批次打码。

Main features

- > Free fall packing of Dolce Gusto and Nespresso capsules.
- > Open box, receive capsules, close box.
- > Hot melt glue system and date printer.



型号 Model	PBX-F
速度 Speed	20-40盒/分 20-40 Carton/minute
包装盒尺寸范围 Carton size	60 - 220(L)*30 - 120(W)*30 - 120(H)mm
控制系统 Controlsystem	PLC(西门子、欧姆龙、施耐德、罗克韦尔)
显示器 Displayer	7寸触摸屏 7 Inch touchscreen
电源要求 Power	AC220V/380V 50Hz/60Hz 7KW
包装尺寸 Dimension	2200(L)*1400(W)*1000(H)mm
机器重量 Weight	500kg
发货重量 Gross weight	560kg

CP5006

全自动六列咖啡胶囊包装生产线 Six Lanes Coffee Capsule Filling And Sealing Machine



主要功能

- > 自动理杯出杯
- > 大储料螺杆上料
- > 伺服驱动螺杆下料
- > 香精液体灌装系统
- > 落杯后封口前全程氮气保护，残氧量小于5%
- > 称重自动剔除系统
- > 出杯后转弯输送带
- > 自动数量分箱装置，省时省力节约装箱成本

Project Consitituion

- > Automatic sorting cup and output cup
- > Big capacity screw convey materials
- > Servo control auger filling powder
- > Filling flavor liquid system
- > Automatic checker weigher system
- > Full nitrogen protection line, residual oxygen less than 5%
- > Cups output to conveyor belt
- > Automatic sorting cup output device, reduct cost

型号 Model	CP5006(卷膜、片膜可选) Precut lid or Roll Film
单次灌装范围 Filling weight range	0-20g*n (可定制) Option
灌装精度范围 Filling accuracy	±0.05-0.15g
最高速度 Speed	200-300 (杯/分钟) Cup per minute
料斗容量 Hopper capacity	2.5L可选110L Option
控制系统 Controlsystem	PLC(欧姆龙、施耐德、罗克韦尔)(OMRON,SCHBEIDER,ROCKWELL)
显示器 Dispalyer	10寸触摸屏 10 Inch touchscreen
电源要求 Power	AC220V/380V 50Hz/60Hz 7KW
机器尺寸 Dimension	3720(L)*1200(W)*2150(H)mm+1750(L)*1200(W)*2150(H)mm
机器重量 Weight	1050kg
发货重量 Gross weight	1150kg



LP02 and LP04

Lavazza point 咖啡胶囊灌装生产线

Four Lanes Lavazza point Coffee Capsule
Production Line



每小时产量大于10800杯

More than 10800 cups per hour

■ 方案构成

- > 空杯提升机
- > 自动理杯输送机
- > 伺服控制螺杆下料机构
- > 两次切膜灌装封口机
- > 成品输送带
- > 自动计量数粒装置
- > 枕式包装机
- > 不合格产品自动剔除废料口装置

■ Project Consituion

- > Empty capsule lifter
- > Automatic sort cup and put out one by one
- > Servo motor driven filler auger
- > Roll film type twice cut and seal system
- > Finished capsule conveyor out
- > Automatic count quantity and connect to flip-flop divertor
- > Pillow bag packing machine
- > Reject unqualified capsules

■ 系统特点

- > 显著提高生产力和缩短生产周期
- > 节约人工，减少生产成本
- > 应用范围广，可告诉自动包装不同种类、品位的产品

■ System Feature

- > Improve productivity and shorten production cycle
- > Save labor and reduce production cost
- > The utility mofel has the adantages of wide application range,high speed and automatic packaging of different kinds of products



型号 Model	LP02 and LP04 (卷膜) Roll film
单次灌装范围 Filling weight range	0-20g
灌装精度范围 Filling accuracy	±0.05~0.15g
最高速度 Speed	150-200 (杯/分钟) Cups/per minute
料斗容量 Hopper capacity	10-24L可选110L
控制系统 Controlsystem	PLC
显示器 Dispalyer	10寸触摸屏 10 Inch touchscreen
电源要求 Power	220V/380V 50Hz/60Hz 5KW
机器尺寸 Dimension	4800mm(L)*2100mm(W)*2700mm(H)
机器重量 Weight	1700kg
发货重量 Gross weight	1900kg

PBX-1

转盘型自动装盒机

Rotary type Automatic Box Packing Machine

包装样品展示
Samples Display



型号 Model	PBX-1
速度 Speed	20-40盒/分 20-40 Carton/minute
包装盒尺寸范围 Carton size	60 - 220(L)*30 - 120(W)*30 - 120(H)mm
控制系统 Controlsystem	PLC(西门子、欧姆龙、施耐德、罗克韦尔)
显示器 Displayer	7寸触摸屏 7 Inch touchscreen
电源要求 Power	AC220V/380V 50Hz/60Hz 7KW
包装尺寸 Dimension	1700(L)*1400(W)*2100(H)mm
机器重量 Weight	500kg
发货重量 Gross weight	560kg

主要特点

- > 机器占地小，成本低
- > 长条形5个10个装纸盒
- > 包括自动开盒，接料，关盒



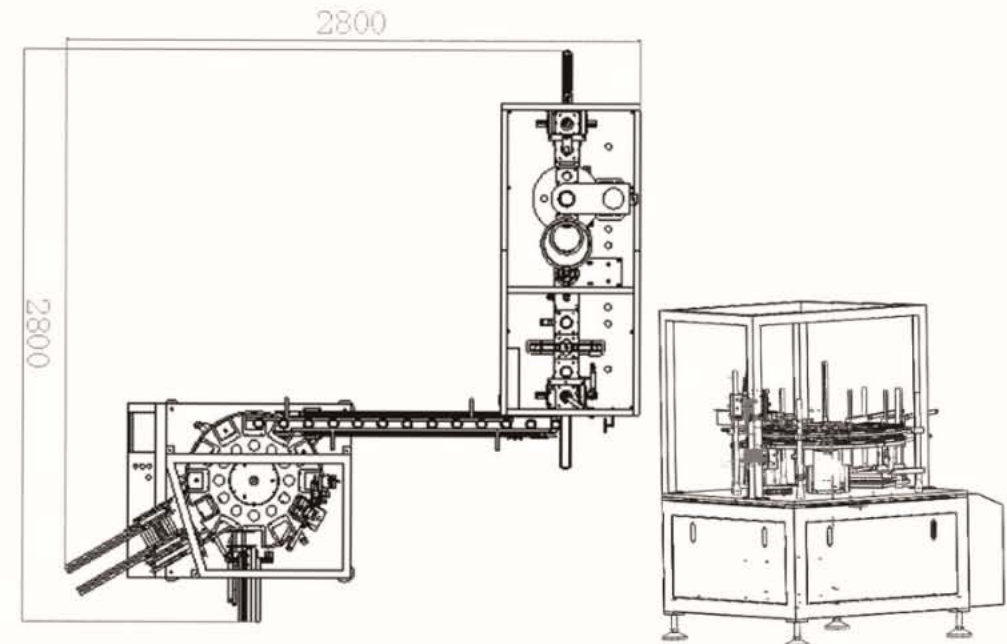

Main features:

- > Small Footprint, low cost
- > Sleeve shape paper tube box for 5ct, 10ct pack.
- > Open box, receive capsules, close box.



可选配件
Optional

<p>灌装系统 Filling system</p>	 <p>强制灌装 compressed type</p>	 <p>弧形灌装 centrifugal head</p>
<p>上料系统 reloading material</p>	 <p>螺杆上料 Screw feeder</p>	 <p>真空上料 Vacuum feeder</p>
<p>香精泵 flavoring liquid dosing</p>	 <p>Liquid flavoring 0.5-1ml</p>	 <p>CANADA HIBAR pump</p>

<p>自动理杯 Automatic sorter (for non-stack capsules)</p>	 <p>振动盘 vibrator small drum</p>	 <p>转筒带提升 rotary drum with lifter conveyor</p>
<p>落杯系统 Cup loading system</p>	 <p>水平落杯 Horizontal loading</p>	 <p>垂直落杯 Vertical loading</p>
<p>除静电 Anti-static bar</p>	 <p>Anti-static bar 静电消除器</p>	 <p>SMC Japan</p>
<p>吸尘清理 Vacuum cleaning</p>		

可选配件
Optional

封口检测 Sealing check camera		
远程连接 Remote Diagnosis		
	有线 Cable wire RJ45	无线 WIFI

远程控制器图
Remote Diagnosis System



其他
Others



油墨喷码机
Ink Jet Printer

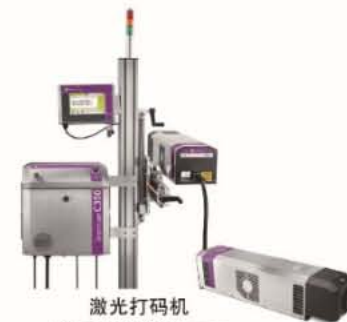

激光打码机
CO2 LASER Burner



活塞空压机
Piston Air Compressor



螺杆空压机
Screw Air Compressor



立式包装机
Vertical Packing Machine VFFS



枕包机
Flow-wrapper machine



制氮机, 气罐
Nitrogen Generator and Air Tank



雀巢胶囊 NESPRESSO CAPSULE



NA-1
without silicon ring
没有硅胶环



NA-2
with silicon ring
带硅胶环



P03



铝胶囊 Aluminum capsule		
型号 Model	NA-1	NA-2
外观 Appearance	没有硅胶环 without silicon ring	有硅胶环 with silicon ring
包装数量 Packing Quantity	2000 each paper carton	5000 pcs each paper carton
包装尺寸及重量 Package Size And Weight	20cmx17cmx20cm, 10kg	45cmx42cmx36cm, 15~20kg
尺寸 Dimension	顶部直径Top Diameter: 37mm; 高度Height: 29mm	
使用材料 Material Use	欧洲进口超纯度铝 Ultra-pure aluminum from Euro	
常规颜色 STD Colors	Standard: gold/red/black/sapphire/sky blue Customize MOQ 300k 标准: 金色/红色/黑色/蓝宝石/天蓝色 定制颜色起订量30万	
兼容咖啡机 Compatible	所有Nespresso原装机型均可 ALL Nespresso original models	

Plastic capsule specification 塑料胶囊规格	
型号 Model	P03
标准颜色 STD Colors	STD Colors 标准颜色 transparent white or customize (MOQ 200k pcs per color) 透明白色或定制您需要的颜色 (每色起订量20万个)
尺寸 Dimension	顶部直径 Top Diameter: 37mm; 高度 Height: 29mm
使用材料 Material Use	全新PP塑料 Brand new PP
包装信息 STD PACKING	4928PCS 每箱, 57cmx31cmx38cm, 11 / 12kg 4928PCS EACH PAPER CARTON, 57cmx31cmx38cm, 11/12kg
兼容咖啡机 Compatible	所有Nespresso原装机型均可 ALL Nespresso original models



预切箔盖 precut foil lid



Our foil original

材料 Material	For PP and PBT	For aluminum capsules
直径 Diameter	37mm	36mm
Item	Precut lid	Roll type film
Thickness	33mic	25mic



Compatible guidance chart

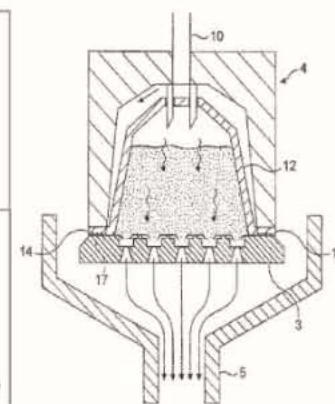

K 杯胶囊 KCUP CAPSULE AND 2.0 LIDS

空的 K 杯 Empty kcup, PP or PSPE



Recycle and Biodegradable

- Made by German solution (machine and tooling)
- EVOH barrier layer (reject oxygen and water)
- PP/PP/Tie/EVOH/Tie/PP/PP 7-layer co-extrusion
- PP and PS
- FDA and BPA FREE

内杯滤纸 Individual filter



Synthetic for coffee



Paper for tea or herbal

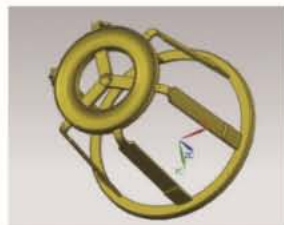

- 6 leg design and stacker type
- Different sizes for different cups available
- FDA and BPA FREE
- Paper filter and Synthetic filter

带滤纸的 K 杯 Ready Kcup with filter inside



- PP based or PS based outside cup
- Barrier type shelf life 18 months
- FDA and BPA FREE
- Inventory ready in USA



Synthetic for coffee



Paper for tea or herbal

包装信息 STD PACKING	每箱4800件 4,800 pcs Per Case, 531 mm x 408 mm x 315 mm
装柜数据 Loading data	288carton in 20GP/ 672cartons in 40HQ/ 784cartons in 45HQ

K杯铝箔盖 K cup foil lid



2.0 compatible
Lavender/orange/brown

DOLCE GUSTO COMPATIBLE SOLUTION



Made in china

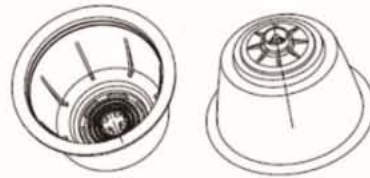

Euro made, China inventory



for coffee



for soluble



Notice: for coffee, machine need extra perforated film cut seal station



CAFFITALY (ALSO KNOWN AS TCHIBO)



LAVAZZA BLUE BARRIER CAPSULES



LAVAZZA POINT (PLASTIC LID CLOSE OR FILTER PAPER ROLL SEAL)



ROLL FILM MATERIAL



方案示例 非标定制自动灌装封口机 (根据客户设计的胶囊量身定制)

Project Case Display: Non-standard Customized Soybean Capsule Filling And Sealing Machine

每小时产量大于10800杯
PCS More than 10800 cups per hour

■ 方案构成

- › 垂直落杯机构 (节约占地面积) (发明专利)
- › 大储量真空上料机
- › 伺服控制螺杆下料机构
- › 自动灌装封口机
- › 成品输送带
- › 定制制氮机+储气罐, 生产后经检测残氧量小于5%, 最大提高保质保鲜效果
- › 自动计量数粒装置
- › 不合格产品自动剔除废料口装置

■ 系统特点

- › 显著提高生产力和缩短生产周期

■ Project Consituion

- › Vertical loading cuo structure(spare space) Invent patent
- › Big capacity vacuum conveyor
- › Servo control auger filling device
- › Automatic filling and sealing machine
- › Finished product convey machine
- › Nitrogen generator+Storage tank
- › Automatic count quantity and weighing device
- › Reject unqualified product

■ System Feature

- › Improve productivity and shorten production cycle

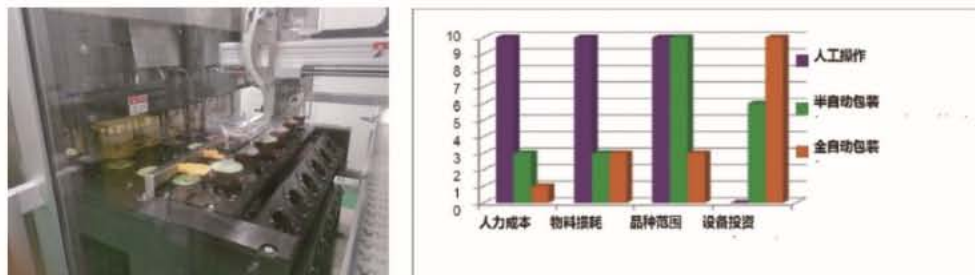

方案示例 坚果类自动称重灌装切膜加盖封口机

Project Case Display: Automatic Nut Cup Filling And Sealing Machine

■ 方案构成

- › 自动落杯机构
- › 多头称自动称重系统+操作平台
- › 氮气接口及全程氮气保护装置
- › 自动切膜封膜机构
- › 自动加盖压盖装置
- › 加长输出操作平台
- › 自动计量数粒装置
- › 不合格产品自动剔除废料口装置

■ 系统特点

- › 显著提高生产力和缩短生产周期
- › 节约人工, 减少生产成本

■ Project Consituion

- › Automatically loading cup device
- › Multthead weigher automatically weighing system,operating platform
- › Notrogen input and full nitrogen protection
- › Automatically add lid and press device
- › Lengthen output operation platform
- › Automatically count quantity annd weighing device
- › Automatically reject bad quality product

■ System Feature

- › Improve productivity and shorten production cycle
- › Save labor and reduce production cost



方案示例 花果茶自动灌装封口装袋生产线

Project Case Display: Automatic Scented Tea Capsule Production Line

■ 方案构成

- 茶叶机 (产量大于7200杯/小时)
- 自动立式制袋机/枕式包装机
- 自动装盒机
- 检重秤
- 喷码机
- 贴标机
- 理盒转盘机



■ 系统特点

- 显著提高生产力和缩短生产周期
- 节约人工, 减少生产成本
- 应用范围广, 可高速自动包装不同种类的产品
- 包装精致、高档

■ Project Consituion

- Tea power packing machine(PCS 7200)
- Horizontal pillow packing machine or bag packing machine
- Automatic cartoning machine
- Weigh checking device
- Ink jet prinert
- Laberling machine
- Automatic sorting carton rotary machine

■ System Feature

- Remarkably improve productivity and shorten production cycle
- Save labor and reduce production cost
- Wide applicable range, suitable for various product
- Exquisite package, High-grade.

方案布置图 Project plan layout

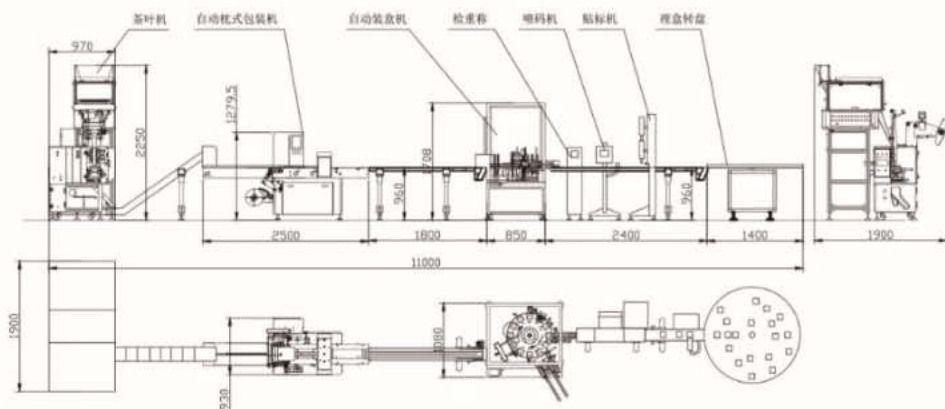

方案示例 设备代理商, 包装材料贸易伙伴

Distributor for machinery, supply sales partner

- Kcup packing machinery resell and aftersales support
- Kcup cup and filter supply
- 2.0 lids printing (low MOQ)
- Co-packing of coffee and tea kcups



- Printing and lids: 2.0 orange lavender and brown
- Machinery demo: Rotary one lane, Linear one lane, Linear 2 lane, Linear 4 lane
- Inventory: Kcups with filter ready

方案示例

零背景，雀巢和K杯咖啡胶囊，袋包咖啡等代工生产企业
From Zero, Nespresso and Kcups capsule
and bag coffee co-packing



方案构成

立式袋包装机 咖啡粉 一台
Kcup生产设备CP5004K, 3条
Nespresso生产线5004N一条
生产力: 年产量5000万

Program composition

Vertical bag packer for ground coffee 1 set
Kcup 5004K, 4 lane machine, 3 plants
Nespresso 4 lane, 1 plant
Capacity: over 50million capsules per year



时间节点:

- 2010-2011 美国PS 杯和嵌入式4环过滤纸
- 2011-2013 美国PS杯和嵌入式6环过滤纸
- 2013-2015 美国PP杯和嵌入式6环过滤纸
- 2015-2016 中国PP杯和嵌入式6环过滤纸
- 2016 till now 中国PP带过滤纸

Timeline:

- 2010-2011: PS kcup (USA) and snap-in 4 leg filter(Expak)
- 2011-2013: PS kcup (USA) and snap-in 6 leg filter(Expak)
- 2013-2015: PP kcup (USA) and snap-in 6 leg filter (Expak)
- 2015-2016: PP kcup(Expak) and snap-in 6 leg filter(Expak)
- 2016 till now: Expak new solution, PP kcup with filter ready



方案示例 俄罗斯项目：定制独特胶囊
Project Russia Customized unique capsule

Step1: based on Nespresso change

Step2: based on Dolce Gusto change



方案示例 Turnkey delivery
Super group- Owl Beverage
Asia milk coffee upon changed kcup system



方案示例 Taiwan tea kcup

各种类型冲泡终端开拓不同渠道
大陆市场的kcup生产由美惠加代工
台湾生产由expak提供支持

Different kcup brewers: cooler dispenser and portable
Podmate co-pack for China market
Taiwan production use Expak solution























方案示例 咖啡机相关 Others you may like



EXHIBITIONS

		MICE-2013 MELBOURNE
SCAA-2014 SEATTLE		
		2014 PROPAK SHANGHAI (Our machinery distributor Mr.kats)
PROPAK 2015 SHANGHAI		
		CAFEEX 2016 SHANGHAI
2016 HOTELEX		
		HOTELEX 2017 SHANGHAI
SCAA-2017 SEATTLE		
		SCA 2018
2018 HOTELEX SHANGHAI		

OUR CUSTOMERS

		Saudi Arabia		Mexico		Canada
		Vietnam		Africa		Fiji
		Taiwan		Philippines		Netherlands
		Toronto		Iran		Vancouver
		Sweden with Rychiger		HAN HUIAI ZONG		Korea
		France		Los Angeles		Russia
		Chicago		India		
		Indonesia				